

SINGLE MILLING CHUCK

MAS403 BT-C

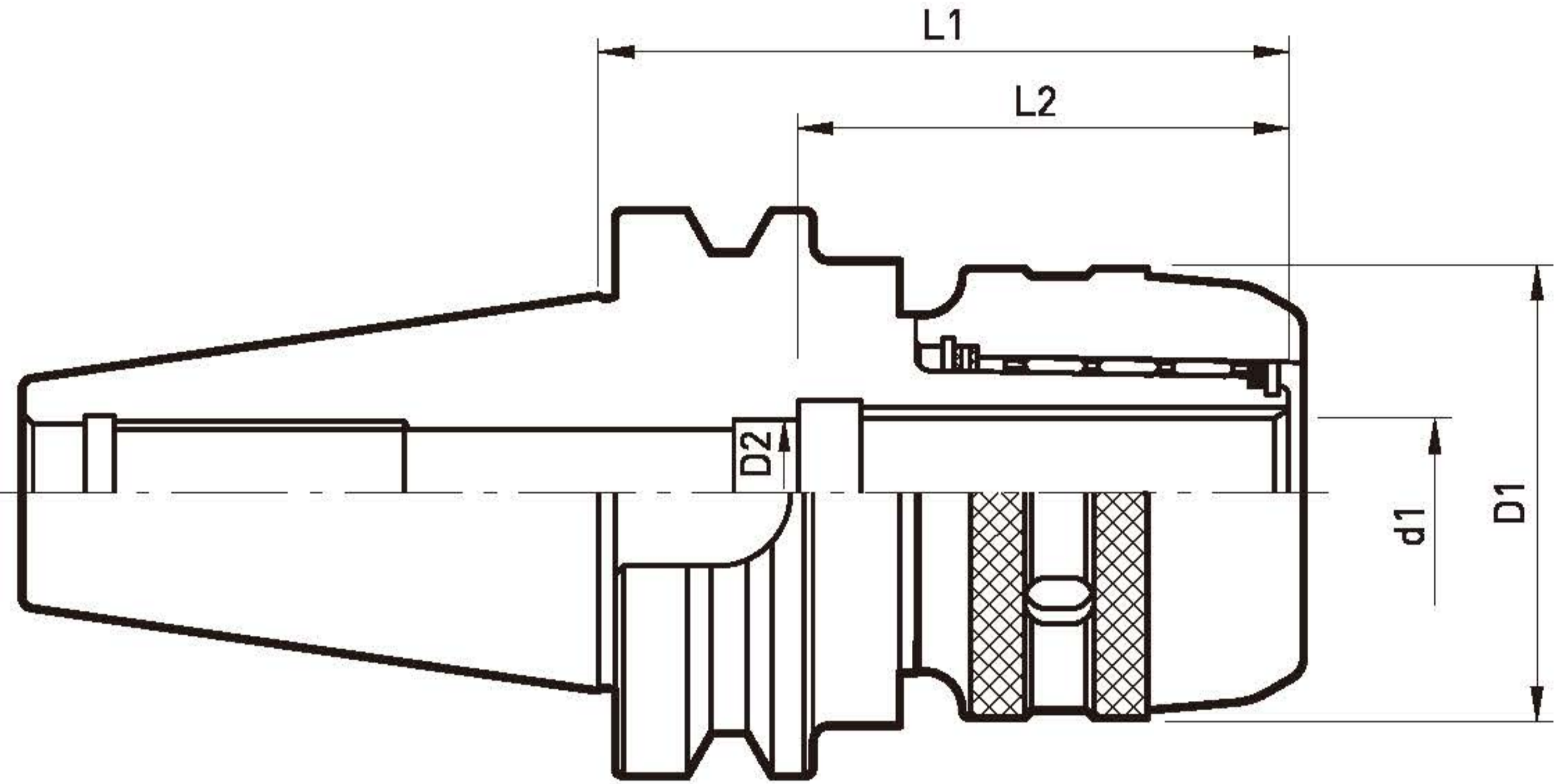

COOLANT

- 내부 급유 (Spindle Through)사용이 가능하며 사용시 ONK Collet를 적용하십시오.
- If you want to use the Milling Chuck with Spindle Through Coolant system, please use our ONK Collet

Taper T.I.R Coolant mm

CODE NO.		d1	D2	D1	L1	L2	COLLET
BT30	C20 - 75	20	19	59	75	65	K20
	C20 - 90				90		
	C20 - 80				80		
BT40	C20 - 90	25	25.5	62	90	70	K25
	C20 - 135				135		
	C25 - 90				90		
	C32 - 105				105		
	C32 - 135				135		
BT50	C32 - 90	32	25	75	90	75	K32
	C32 - 105				105		
	C32 - 135				135		
	C20 - 105	20	19	59	105	65	K20
	C20 - 150				150		
	C25 - 105	25	25.5	62	105	70	K25
	C25 - 135				135		
	C32 - 110	32	25	75	110	75	K32
	C32 - 135				135		
C32 - 165	165						
C42 - 110	42	25	94	110	85	K42	
C42 - 135				135			
C42 - 165				165			

SINGLE MILLING CHUCK

DIN69871 SK-C

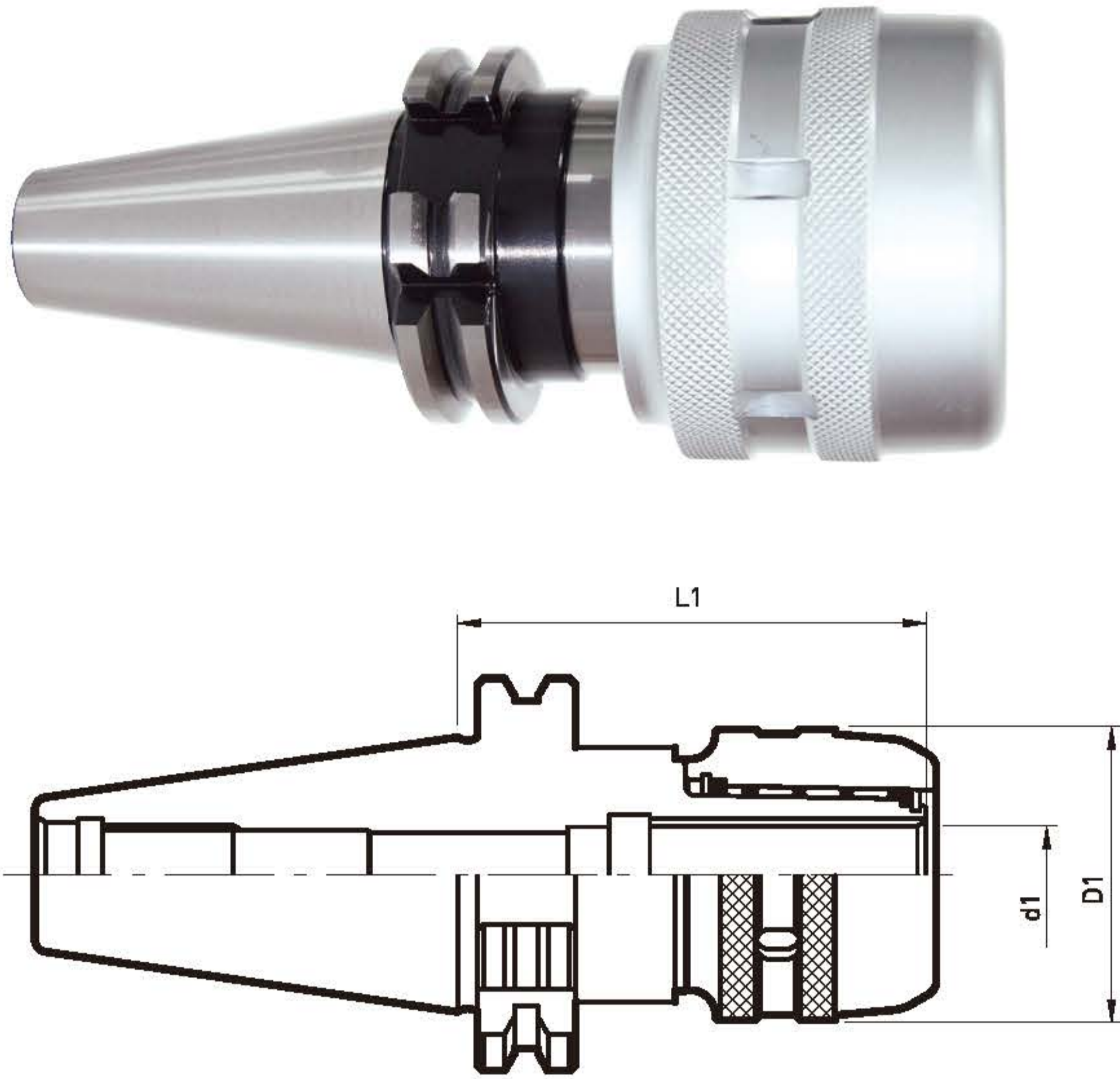

Taper Coolant mm

CODE NO.		d1	D1	L1	COLLET
SK40	C20 - 105	20	59	105	K20
	C25 - 105	25	62		K25
	C32 - 105	32	75	135	K32
	C32 - 135				
SK50	C20 - 105	20	59	105	K20
	C25 - 105	25	62		K25
	C32 - 105	32	75	135	K32
	C32 - 135				
	C32 - 165			165	
	C42 - 115	42	94	115	K42
	C42 - 135			135	
	C42 - 165			165	

DIN69893 HSK-C

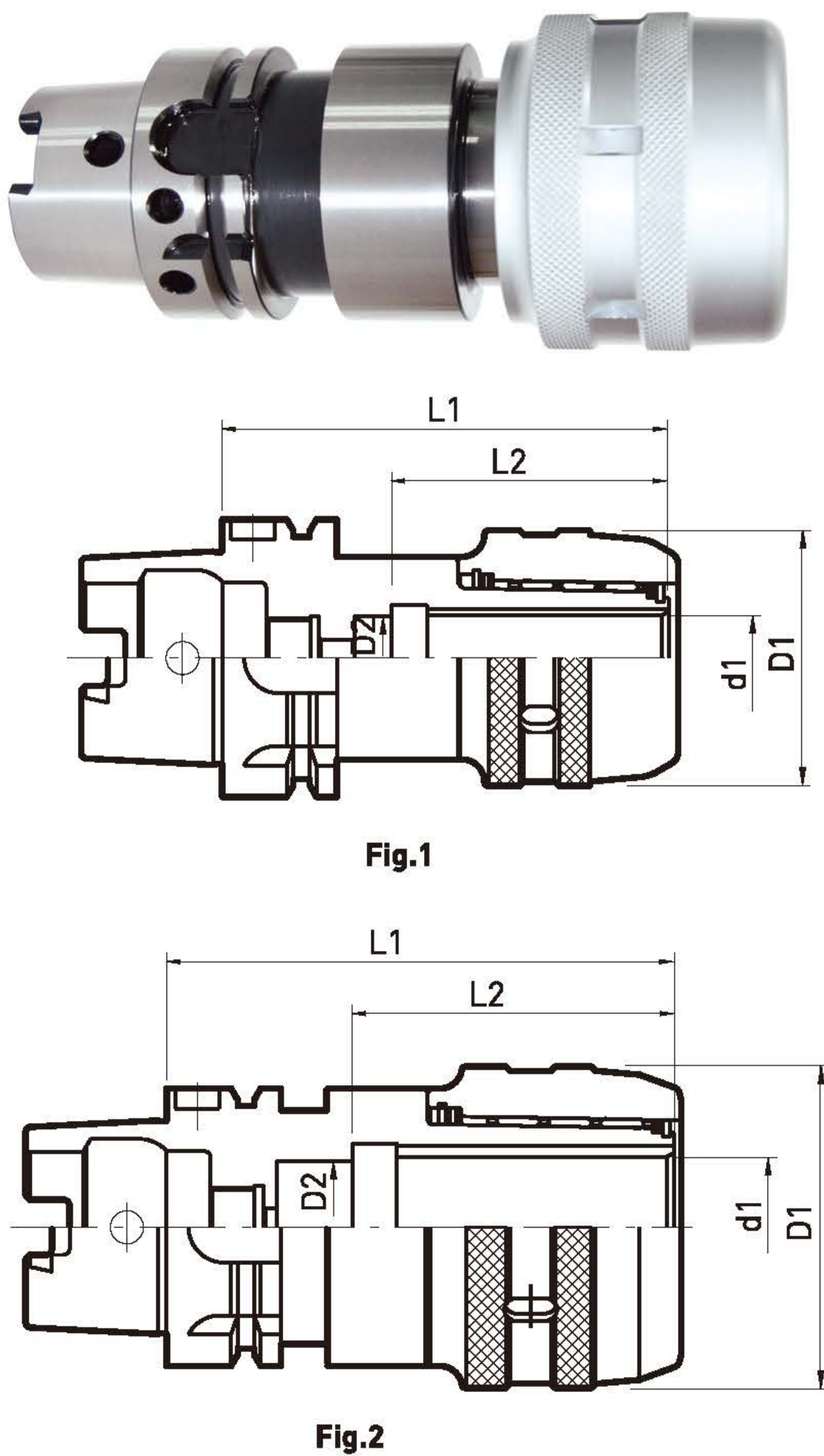

Taper Coolant mm

CODE NO.		FIG	d1	D2	D1	L1	L2
HSK50A	C20 - 100	1	20	19	59	100	65
	C20 - 105				105		
HSK63A	C32 - 130	2	32	25	75	130	75
	C20 - 110	1	32	25	59	110	65
C32 - 135	75				135	75	
C42 - 135	94				135	85	

COOLANT

- 내부 급유 (Spindle Through)사용이 가능하며 사용시 ONK Collet를 적용하십시오.
- If you want to use the Milling Chuck with Spindle Through Coolant system, please use our ONK Collet

MILLING CHUCK(NC용 COLLET)

NK

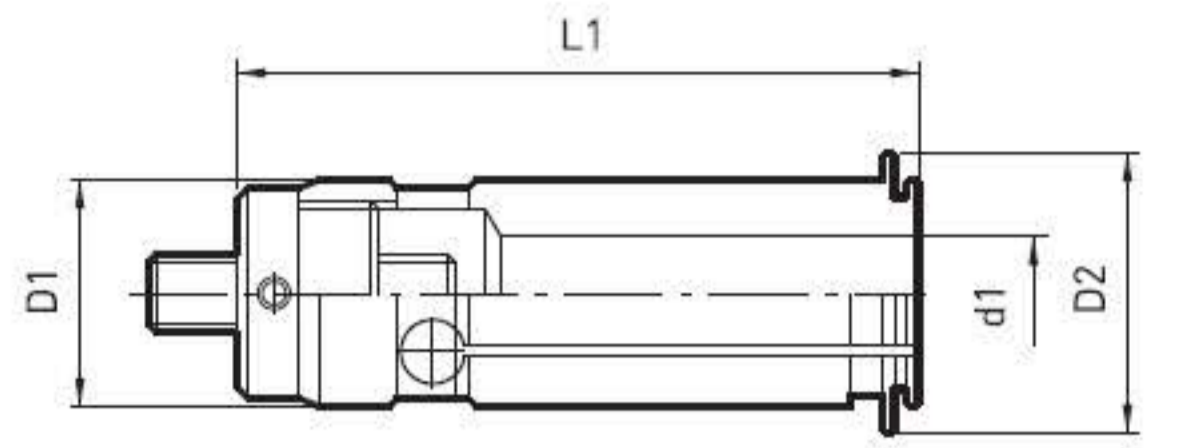

CODE NO. (d1)		D1	D2	L1
NK20	6,8,10,12,16	20	24	66
NK32	6,8,10,12,16,20,25	32	37	80
NK42	6,8,10,12,16,20,25,32	42	48	87

MILLING CHUCK(STRAIGHT COLLET)

K

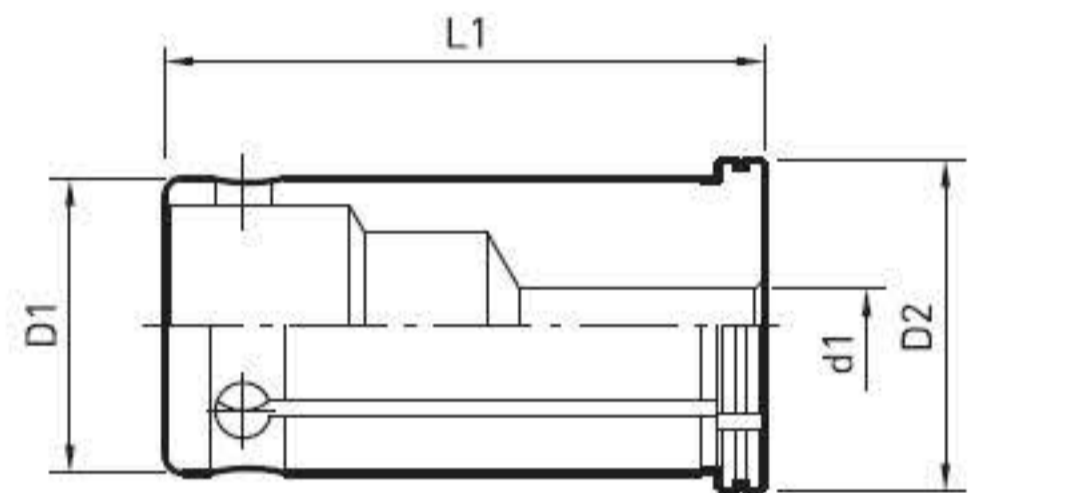

CODE NO. (d1)		D1	D2	L1
K20	6,8,10,12,16	20	24	50
K32	6,8,10,12,16,20,25	32	36	65
K42	6,8,10,12,16,20,25,32	42	48	75

MILLING CHUCK(COOLANT용 COLLET)

ONK

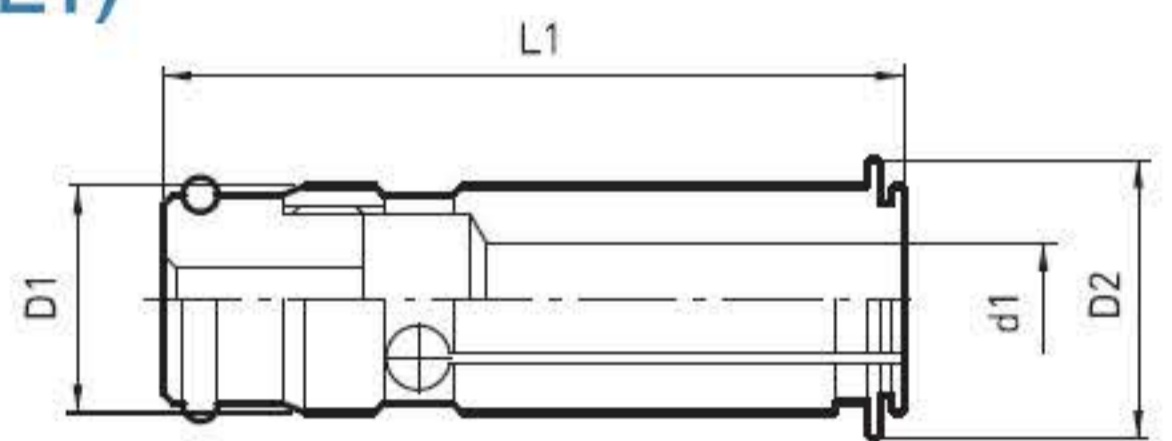

CODE NO. (d1)		D1	D2	L1
ONK20	6,8,10,12,16	20	24	77
ONK32	6,8,10,12,16,20,25	32	37	90
ONK42	6,8,10,12,16,20,25,32	42	48	97

- ONK 콜릿트는 Single Milling Chuck (C Type) 및 Double Bearing Milling Chuck (DBC Type)에 조합하여 Oil Hole(internal Cooling) 공구를 효율적으로 사용합니다.
- ONK collet is able to apply for Spindle Coolant system with Milling Chuck and Double Bearing Milling Chuck