

# HYDRAULIC EXPANSION CHUCK COLLET – Reduction Sleeve (Oil hole type)

OD – Coolant waterproof design

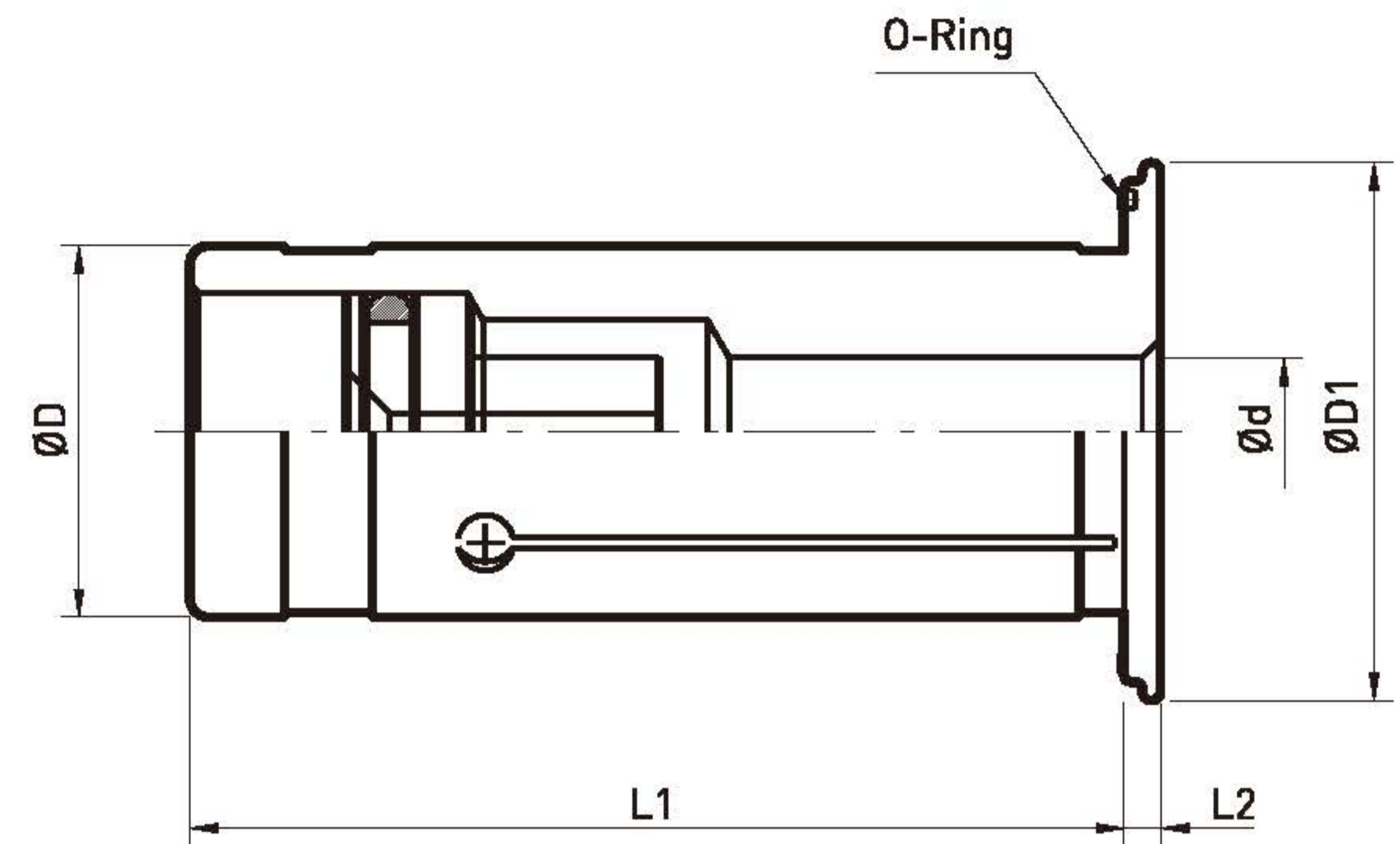

## 특징

-유압척 용 OD COLLET는 내경 Ø에 따라 6등분의 분할로 되어 있어 절삭공구의 Shank를 고르게 Chucking 해주며, 고정밀도 (동심)유지를 위하여 내경 Ø의 칩수 공차를 AA급으로 관리하고 있으며 절삭유 사용시 절삭유 누수율 100% 차단을 구현하고 있습니다.

## Feature

1. ID(inner bore) size can reducible by using reduction sleeve OD12/OD20/OD32
2. OD type is 100% coolant waterproof
3. There is a little bit tighten when insert the reduction sleeve into the chuck due to high precision tolerance of reduction sleeve and chuck.
4. Please insert the reduction sleeve into the chuck after insert a cutting tool into the reduction sleeve.

T.I.R  $\geq 5\mu\text{m}/3\times D$  mm

CODE No.		d	D	D1	L1	L2
OD12	3	3	12	21	45	2
	4	4				
	5	5				
	6	6				
	8	8				
OD20	3	3	20	29	50.5	2
	4	4				
	5	5				
	6	6				
	8	8				
	10	10				
	12	12				
16	16					
OD32	6	6	32	39	60.5	3
	8	8				
	10	10				
	12	12				
	16	16				
	20	20				
25	25					