

**Mandrino di bloccaggio statico a 3 griffe, pneumatico-idraulico - MPAF/3**  
**Stationary 3-jaws-Clamping-Chuck, pneumatic-hydraulic- MPAF/3**  
**Stationäre 3-Backen-Spannfutter, pneumatisch-hydraulisch - MPAF/3**  
**Mandrine de serrage pneumatique-hydraulique statique, 3 mors - MPAF/3**



### Dati tecnici

- Pressione d'esercizio: 2 ... 12 bar in pneumatica, max 50 bar in idraulica
- Precisione di ripetibilità: MPAF/3 - 115 ... 155 0.02 mm  
MPAF/3 - 200 ... 250 0.03 mm  
MPAF/3 - 305 ... 450 0.05 mm con 100 cicli
- Temperatura d'esercizio: da 5°C a 60° C
- Sistema di funzionamento: cinematica a piani inclinati con guida forzata e trasmissione della forza applicata alle superfici
- Apertura/chiusura parallela con corse totali dei carrellini da 5 a 44 mm
- Applicazione tramite: fori per spine H7 centraggio H6
- Materiale corpo: acciaio trattato
- Materiale parti funzionali: acciaio trattato
- Azionamento: olio filtrato (10mm) viscosità 46 mm<sup>2</sup>/s a 40° ISO VG; max 60° C; aria compressa filtrata (10µm), secca o lubrificata
- Attacchi: laterali - base
- Manutenzione: lubrificare tramite ingrassatori ogni 5.000 cicli in lavorazione, ogni 100.000 cicli con presa di manipolazione

### Technische Daten

- Betriebsdruck: 2 ... 12 bar in pneumatisch, max 50 Bar hydraulisch
- Wiederholgenauigkeit: MPAF/3 - 115 ... 155 0.02 mm  
MPAF/3 - 200 ... 250 0.03 mm  
MPAF/3 - 305 ... 450 0.05 mm über 100 Zyklen
- Betriebstemperaturbereich: von 5°C bis 60° C
- Kinematik/Futterkolben: Keilhakenprinzip, für hohe kraftübertragung und zentrisches Spannen
- Parallel Öffnen/Schliessen, Gesamthub der Schlitten 5 bis 44 mm
- Gehäuse ausgerichtet durch Verstiftung H7 und Zentrierung H6
- Gehäuse und Funktionsteile aus gehärtetem Stahl
- Betätigung: hydraulisch über gefiltertes Öl (10mm) Viskosität 46 mm<sup>2</sup>/s bei 40° ISO VG; Max 60° C; pneumatisch über gefilterte Druckluft (10mm), trocken oder geölt
- Druckluftanschlüsse: Über die Seitenflächen - Grundflächen
- Schmierintervalle: bei Einsatz auf Zerspanungsmaschine alle 5.000 Schaltspiele, bei Handhabungsprozessen alle 100.000 Schaltspiele

### Technical data

- Operating pressure range: 2 ... 12 bar with air, max 50 bar with oil
- Repeatability accuracy: MPAF/3 - 115 ... 155 0.02 mm  
MPAF/3 - 200 ... 250 0.03 mm  
MPAF/3 - 305 ... 450 0.05 mm with 100 cycles
- Operating temperature range: from 5°C to 60° C
- Operating principle: wedge and piston design with mechanically restricted guidance
- Stroke range from 5 to 44 mm
- Mounting: by means of bores for H7 pins and centering
- Housing material: hardened steel
- Material for functional parts: hardened steel
- Actuation: filtered hydraulic oil (10mm) viscosity 46 mm<sup>2</sup>/s at 40° ISO VG; max 60°C, filtered compressed air (10mm) dry or lubricated
- Connections: sides - bases
- Maintenance: relubrifed via lubrication-nipples, every 5.000 cycles for tool clamping, every 100.000 in handling

### Données techniques

- Pression de service: 2 ... 12 bar en pneumatique, max 50 bar en hydraulique
- Précision de répétabilité: MPAF/3 - 115 ... 155 0.02 mm  
MPAF/3 - 200 ... 250 0.03 mm  
MPAF/3 - 305 ... 450 0.05 mm sur 100 cycles
- Température de service: de 5°C à 60° C
- Système de fonctionnement: piston et noix de commande à rampe
- Course parallèle des mors élevée de 5 à 44 mm
- Centrage par: trous pour goupilles H7 et centrage H6
- Matière des pièces fonctionnelles: Acier trempé et rectifié
- Matière du corps: Acier trempé et rectifié
- Fonctionnement: huile filtré (10mm) viscosité 46 mm<sup>2</sup>/s à 40° ISO VG; Max 60° C; air comprimé filtré (10mm), sec ou lubrifié
- Conduites: sur la côté - sur la base
- Maintenance: lubrification par graisseurs d'huile tous les 5.000 cycles avec serrage de pièces à usiner, les 100.000 cycles avec serrage de manipulation

**Mandrino di bloccaggio statico a 3 griffe, pneumatico-idraulico - MPAF/3**  
**Stationary 3-jaws-Clamping-Chuck, pneumatic-hydraulic- MPAF/3**  
**Stationäre 3-Backen-Spannfutter, pneumatisch-hydraulisch - MPAF/3**  
**Mandrine de serrage pneumatique-hydraulique statique, 3 mors - MPAF/3**

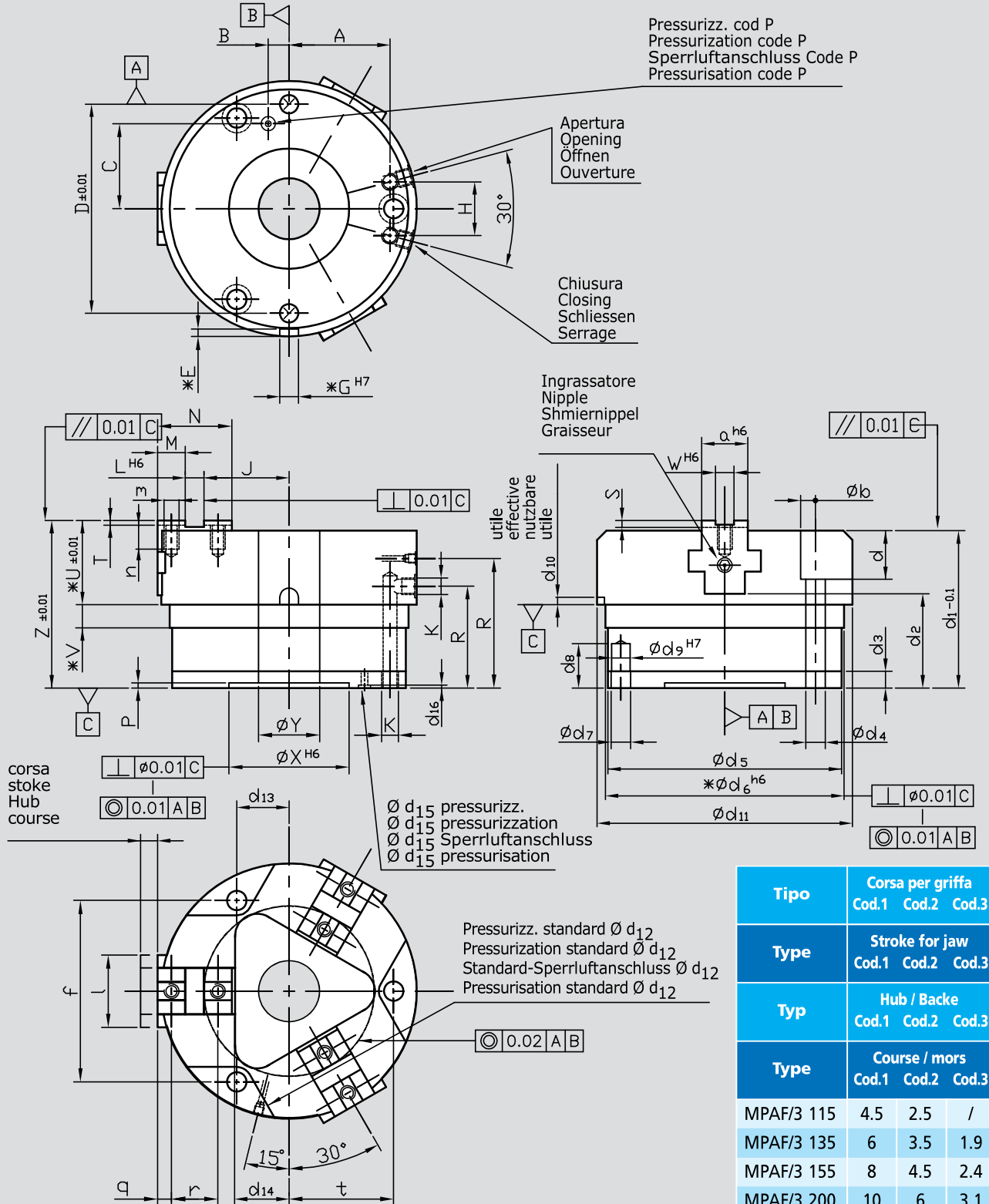

Tipo	Corsa per griffa		
	Cod.1	Cod.2	Cod.3
MPAF/3 115	4.5	2.5	/
MPAF/3 135	6	3.5	1.9
MPAF/3 155	8	4.5	2.4
MPAF/3 200	10	6	3.1
MPAF/3 250	13	7.5	3.9
MPAF/3 310	16.5	9.5	5
MPAF/3 380	19	11	5.7
MPAF/3 450	22	12.5	/

- Su richiesta : quote E, V, a,  $d_6$  in tolleranza - cod. FC
- On request : levels E, V, a,  $d_6$  in tolerance - code FC
- Auf Anforderung : Massen E, V, a,  $d_6$  nach Toleranz - Code FC
- Sur demande : côtes E, V, a,  $d_6$  en tolérance - code FC

Type	A	B	C	D	E	G	H	J	L	M	N	P	R	S	T	U	V	Z	Y	X	K	W	a
MPAF/3-115	42	12	44	92	3,5	8	23	39	8	11	30	3.5	55	4	3	47	12	92	15	40	1/8"G	8	20
MPAF/3-135	50	13	52	106	4,5	10	30	45	10	13	36	3.5	64	6	4	56	16	108	20.5	50	1/8"G	10	25
MPAF/3-155	60	17	61	126	4.8	12	33	56	10	15	40	4	70	7	4	67	20	125	30.5	65	1/8"G	12	30
MPAF/3-200	77	21	77	160	6.5	12	42	73	12	19	50	4.5	81	8	5	76	24	144	41	100	1/4"G	14	35
MPAF/3-250	96	26	97	200	7.5	16	52	91	14	23	60	4.5	95	9	5	93	30	174	51	115	3/8"G	17	40
MPAF/3-310	122	33	123	260	7.5	20	66	112	20	26	72	5.5	113	9	6	114	35	212	66	130	3/8"G	21	45
MPAF/3-380	141	38	141	300	18	20	76	142	20	33	86	6.5	128	13	7	132	40	242	96	160	1/2"G	21	50
MPAF/3-450	166	45	166	360	19	24	90	165	28	36	100	8	149	15	8	165	40	279	116	180	3/4"G	28	60

Type	b	d	d <sub>1</sub>	d <sub>2</sub>	d <sub>3</sub>	d <sub>4</sub>	d <sub>5</sub>	d <sub>6</sub>	d <sub>7</sub>	d <sub>8</sub>	d <sub>9</sub>	d <sub>10</sub>	d <sub>11</sub>	d <sub>12</sub>	d <sub>13</sub>	d <sub>14</sub>	d <sub>15</sub>	d <sub>16</sub>	f	l	m	n	q	Max finger lenght
MPAF/3-115	14	23	86	55	11	9	104	106	9	25	8	7	114	M5	23	27	6	0.7	79.5	30	M6	11	6	40
MPAF/3-135	17	30	100	64	12	11	122	124	11	30	10	8	134	M5	26.5	31	7	0.7	92	38	M8	14	7	40
MPAF/3-155	19	38	116	72	13	13	142	144	13	32	12	10	154	M5	31.5	40	8	0.7	109	44	M8	14	7	55
MPAF/3-200	25	40	134	81	16	17	182	184	13	36	12	10	198	1/8"G	40	53	10	1.3	138.5	50	M10	20	10	70
MPAF/3-250	25	52	163	95	18	17	230	232	17	46	16	12	248	1/8"G	50	67	12	1.3	173	59	M12	24	10	75
MPAF/3-310	32	70	201	115	24	21	288	290	21	56	20	16	306	1/8"G	65	85	12	1.3	225	68	M16	28	14	75
MPAF/3-380	38	80	227	127	26	25	336	338	21	60	20	18	378	1/8"G	75	108	14	1.3	260	74	M16	28	17	80
MPAF/3-450	42	100	262	145	29	28	398	400	25	74	24	20	446	1/4"G	90	128	16	1.3	312	88	M20	34	18	85

Tipo	r	t	Forza di serraggio a 6 bar (N) cod. 3 cod. 2		Forza di serraggio a 50 bar (N) cod. 1 cod. 2		Tempo circa (sec.) apertura chiusura		Consumo per corsa x 2 (cm <sup>3</sup> ) aria olio		Massa (Kg)		
Type	r	t	Gripping force at 6 bar (N) code 3 code 2		Gripping force at 50 bar (N) code 1 code 2		Approx. time (sec.) opening closing		Consumption for stroke x 2 (cm <sup>3</sup> ) air oil		Mass (Kg)		
Typ	r	t	Spannkraft bei 6 Bar (N) Code 3 Code 2		Spannkraft bei 50 Bar (N) Code 1 Code 2		Schließzeit (Sec.) Öffnen Schließen		Verbrauch Hub x 2 (cm <sup>3</sup> ) Luft Öl		Masse (Kg)		
Type	r	t	Force de serrage à 6 bar (N) code 3 code 2		Force de serrage à 50 bar (N) code 1 code 2		Temps environ (sec.) ouverture serrage pn id pn id		Consommation course x 2 (cm <sup>3</sup> ) air huile		Masse en Kg		
MPAF/3-115	18	46	/	4260	6600	13500	0.1	0.15	0.1	0.15	32	16	5.5
MPAF/3-135	22	53	13500	7020	8200	16500	0.15	0.25	0.15	0.2	127	49	9
MPAF/3-155	26	63	19100	10000	11100	22700	0.25	0.45	0.2	0.35	236	93	13.5
MPAF/3-200	30	80	25800	13470	13900	28500	0.35	0.6	0.3	0.4	426	180	25
MPAF/3-250	40	100	42800	22320	27700	56600	0.4	0.7	0.35	0.5	898	376	51
MPAF/3-310	44	130	69500	36420	45300	93200	0.6	1	0.5	0.7	1836	678	91
MPAF/3-380	52	150	91700	48050	63500	130800	0.7	1.35	0.6	0.95	2810	1070	144
MPAF/3-450	64	180	/	69200	100100	206000	0.8	1.2	0.7	0.9	4560	1755	228

- Peso trasportabile calcolato con  $\mu = 0.1$  e  $fs = 2$ . Con presa geometrica il valore potrà essere incrementato. La forza di presa è la somma aritmetica delle singole forze delle dita alla distanza di 15 mm dal piano griffa a 6/50 bar.
- Workpiece weight value at  $\mu = 0.1$  e  $fs = 2$ . In case of form fit clamping these values may be higher. Gripping force is the arithmetic sum of the individual forces occurring at fingers, distance 15mm at 6/50 bar.
- Empfehlung für max. Werkstückgewicht gerechnet mit  $\mu = 0.1$   $fs = 2$ . Bei Formschluss sind größere Massen möglich. Die Greifkraft ist die arithmetische Summe der an den Greifbacken auftretenden Einzelkräfte in Abstand 15mm bei 6/50 bar.
- Masse transportable calculée avec  $\mu = 0.1$  e  $fs = 2$ . Avec Prétension géométrique la masse pourrait être supérieure. La force de serrage est la somme arithmétique des forces individuelles des mors qui se forme à 15 mm à 6/50 bar.

Lubrificazione - cod. CL      Lubrification - cod. CL  
Zentralschmierung - Code CL      Lubrication - cod. CL

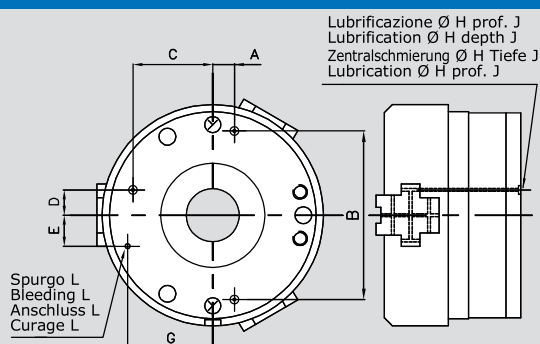

Type	A	B	C	D	E	G	H	J	L
MPAF/3-115	13	91	46	12	15	41	6	0.7	M5
MPAF/3-135	13	104	52	15	22	50	7	0.7	M5
MPAF/3-155	15	122	60	18	27	57	8	0.7	M5
MPAF/3-200	57	113	77	21	27	75	10	1.3	1/8"G
MPAF/3-250	70	144	98	24	34	95	12	1.3	1/8"G
MPAF/3-310	85	188	124	27	43	120	12	1.3	1/8"G
MPAF/3-380	98	216	142	30	50	136	14	1.3	1/8"G
MPAF/3-450	115	256	168	36	59	162	16	1.3	1/8"G

**Mandrino di bloccaggio statico a 3 griffe, pneumatico-idraulico - MPAF/3**  
**Stationary 3-jaws-Clamping-Chuck, pneumatic-hydraulic- MPAF/3**  
**Stationäre 3-Backen-Spannfutter, pneumatisch-hydraulisch - MPAF/3**  
**Mandrine de serrage pneumatique-hydraulique statique, 3 mors - MPAF/3**

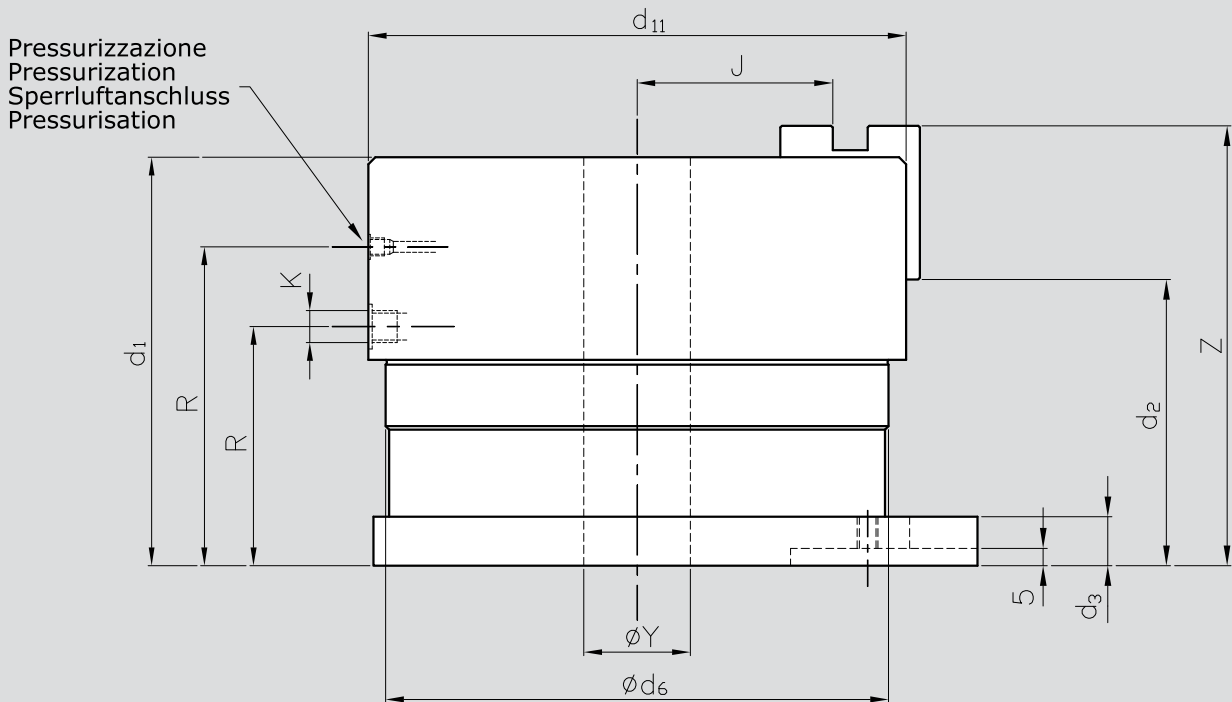
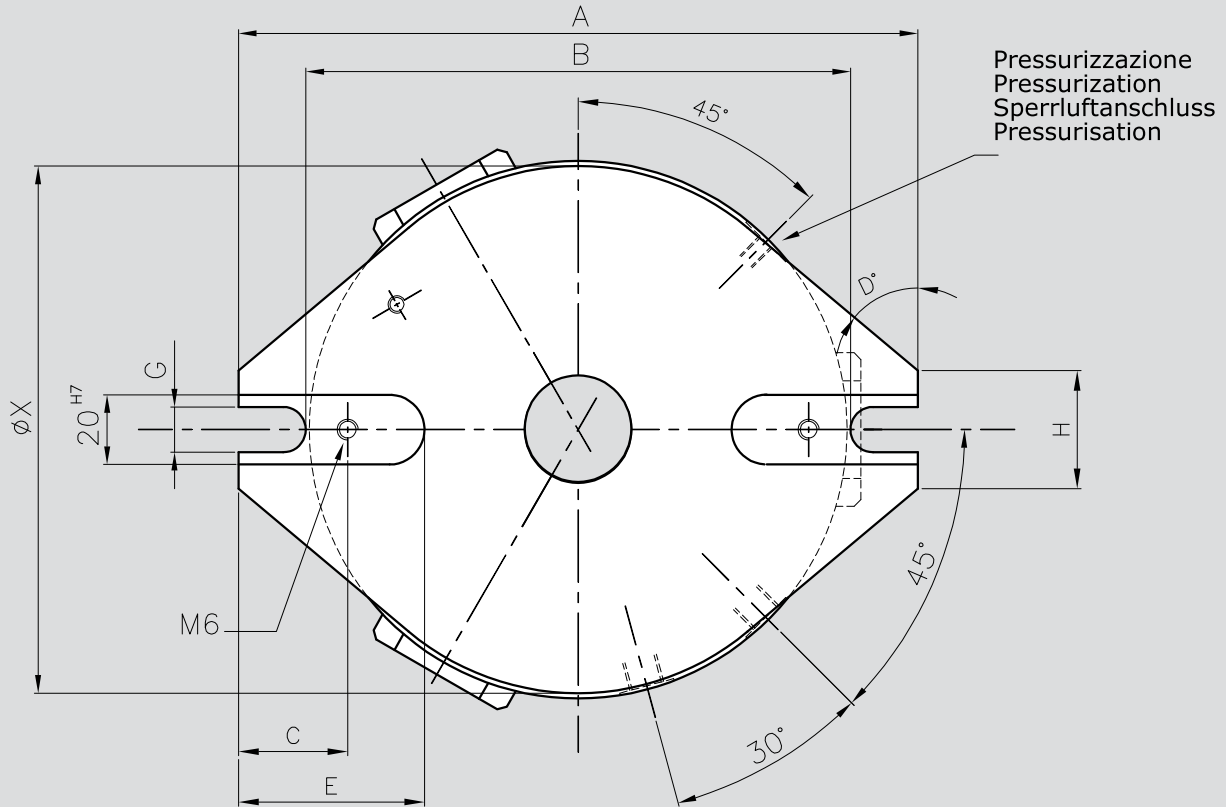

**Mandrino di bloccaggio statico a 3 griffe, pneumatico-idraulico - MPAF/3**  
**Stationary 3-jaws-Clamping-Chuck, pneumatic-hydraulic- MPAF/3**  
**Stationäre 3-Backen-Spannfutter, pneumatisch-hydraulisch - MPAF/3**  
**Mandrines de serrage pneumatique-hydraulique statique, 3 mors - MPAF/3**

Versione MPAF/3 - FL  
Version MPAF/3 - FL

Version MPAF/3 - FL  
Version MPAF/3 - FL

Type	A	B	C	D	E	G	H	J	R	Z	Y	X	K	d <sub>1</sub>	d <sub>2</sub>	d <sub>3</sub>	d <sub>6</sub>	d <sub>11</sub>
MPAF/3-FL-115	155	118	30.5	55	52.5	13	23.3	39	58	95	15	108	1/8''G	89	58	14	106	114
MPAF/3-FL-135	170	133	30.5	50	52.5	13	21.8	45	66	110	20.5	126	1/8''G	102	74	14	124	134
MPAF/3-FL-155	195	156	31.5	50	53.5	13	33.5	56	71	126	30.5	151	1/8''G	117	82	14	144	154
MPAF/3-FL-200	248	200	36	50	58	15	45.2	73	81	144	41	194	1/4''G	134	91	16	184	198
MPAF/3-FL-250	295	248	35.5	50	57.5	15	63.2	91	95	174	51	238	3/8''G	163	95	18	232	248
MPAF/3-FL-310	365	314	38.5	50	60.5	18	77.5	112	113	212	66	294	3/8''G	201	136	22	290	306
MPAF/3-FL-380	400	350	41	50	63	18	103	142	128	242	96	336	1/2''G	227	142	26	338	378

Tipo	Forza di serraggio a 6 bar (N)		Forza di serraggio a 50 bar (N)		Tempo circa (sec.)				Consumo per corsa x 2 (cm <sup>3</sup> )		Massa (Kg)
	cod. 3	cod. 2	cod. 1	cod. 2	apertura		chiusura		aria	olio	
Type	Gripping force at 6 bar (N)		Gripping force at 50 bar (N)		Approx. time (sec.)				Consumption for stroke x 2 (cm <sup>3</sup> )		Mass (Kg)
Typ	Spannkraft bei 6 Bar (N)		Spannkraft bei 50 Bar (N)		öffnen		schließen		Luft	Öl	
Type	Force de serrage à 6 bar (N)		Force de serrage à 50 bar (N)		Temps environ (sec.)				Consommation course x 2 (cm <sup>3</sup> )		Masse en Kg
Type	code 3	code 2	code 1	code 2	ouverture		serrage		air	huile	
					pn	id	pn	id			
MPAF/3-FL-115	/	4260	6600	13500	0.1	0.15	0.1	0.15	32	16	6
MPAF/3-FL-135	13500	7020	8200	16500	0.15	0.25	0.15	0.2	127	49	10
MPAF/3-FL-155	19100	10000	11100	22700	0.25	0.45	0.2	0.35	236	93	15
MPAF/3-FL-200	25800	13470	13900	28500	0.35	0.6	0.3	0.4	426	180	26
MPAF/3-FL-250	42800	22320	27700	56600	0.4	0.7	0.35	0.5	898	376	52
MPAF/3-FL-310	69500	36420	45300	93200	0.6	1	0.5	0.7	1836	678	93
MPAF/3-FL-380	91700	48050	63500	130800	0.7	1.35	0.6	0.95	2810	1070	146

- Peso trasportabile calcolato con  $\mu = 0.1$  e  $f_s = 2$ . Con presa geometrica il valore potrà essere incrementato. La forza di presa è la somma aritmetica delle singole forze delle dita alla distanza di 15 mm dal piano griffa a 6/50 bar. Workpiece weight value at  $\mu = 0.1$  e  $f_s = 2$ . In case of form fit clamping these values may be higher. Gripping force is the arithmetic sum of the individual forces occurring at fingers, distance 15mm at 6/50 bar.
- Empfehlung für max. Werkstückgewicht gerechnet mit  $\mu = 0.1$   $f_s = 2$ . Bei Formschluss sind größere Massen möglich. Die Greifkraft ist die arithmetische Summe der an den Greifbacken auftretenden Einzelkräfte in Abstand 15mm bei 6/50 Bar.
- Masse transportable calculée avec  $\mu = 0.1$  e  $f_s = 2$ . Avec Prétension géométrique la masse pourrait être supérieure. La force de serrage est la somme arithmétique des forces individuelles des mors qui se forme à 15 mm à 6/50 bar.

Type	Stroke for jaw		
	Cod.1	Cod.2	Cod.3
MPAF/3 115	4.5	2.5	/
MPAF/3 135	6	3.5	1.9
MPAF/3 155	8	4.5	2.4
MPAF/3 200	10	6	3.1
MPAF/3 250	13	7.5	3.9
MPAF/3 310	16.5	9.5	5
MPAF/3 380	19	11	5.7

**Mandrini multipli di bloccaggio statici - MPAF13-DV**  
**Stationary multiple clamping chuck - MPAF13-DV**  
**Stationäre Mehrfachspannfutter - MPAF13-DV**  
**Unités multiples pour centres d'usinage - MPAF13-DV**

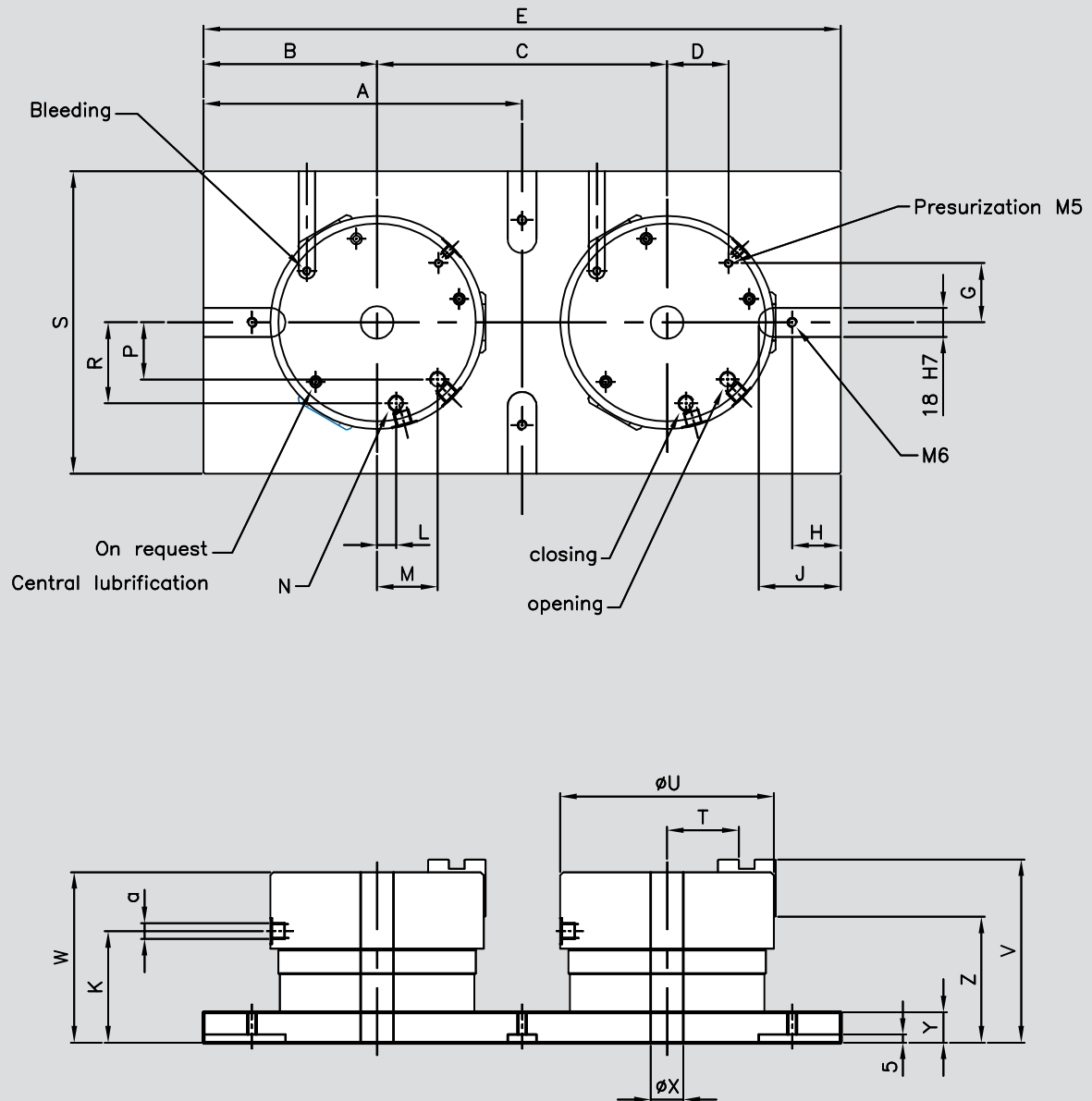

**Mandrini multipli di bloccaggio statici - MPAF/3-DV**  
**Stationary multiple clamping chuck - MPAF/3-DV**  
**Stationäre Mehrfachspannfutter - MPAF/3-DV**  
**Unités multiples pour centres d'usinage - MPAF/3-DV**

Versione MPAF/3 - DV  
Version MPAF/3 - DV

Version MPAF/3 - DV  
Version MPAF/3 - DV

Type	A	B	C	D	E	G	H	J	L	M	N	P	R	S	T	U	V	Z	X	Y
MPAF/3-135-DV	200	109	182	38.5	400	37.2	30.5	51.5	12	38	1/8	26.5	35.8	190	45	134	115	59	20.5	19
MPAF/3-155-DV	230	118	224	44.3	460	45.2	31.5	52.5	15.7	44.3	1/8	31.5	43.7	220	56	154	135	68	30.5	23
MPAF/3-200-DV	292.5	155.5	274	56.2	585	56.7	36	57	20.3	56.7	1/4	40	56.2	260	73	18	156	80	41	28
MPAF/3-250-DV	330	168	324	71	660	71	35.5	56.5	25.5	70.5	3/8	50	70.1	320	91	248	188	95	51	32
MPAF/3-310-DV	390	203	374	90	780	90.1	38.5	59.5	32.4	89.6	3/8	65	89.2	380	112	306	222	108	66	32

Type	W	K	a
MPAF/3-DV-135	107	70	1/8
MPAF/3-DV-155	126	80	1/8
MPAF/3-DV-200	146	93	1/4
MPAF/3-DV-250	177	109	3/8
MPAF/3-DV-310	211	122	3/8

Tipo	Corsa per griffa			Forza di serraggio a 6 bar (N)		Forza di serraggio a 50 bar (N)		Tempo circa (sec.)				Consumo per corsa x 2 (cm <sup>3</sup> )		Massa (Kg)
	cod. 1	cod. 2	cod. 3	cod. 3	cod. 2	cod. 1	cod. 2	apertura		chiusura		aria	olio	
Type	Stroke for jaw			Gripping force at 6 bar (N)		Gripping force at 50 bar (N)		Approx. time (sec.)				Consumption for stroke x 2 (cm <sup>3</sup> )		Mass (Kg)
	code 1	code 2	code 3	code 3	code 2	code 1	code 2	opening		closing		air	oil	
Typ	Hub / Backe			Spannkraft bei 6 Bar (N)		Spannkraft bei 50 Bar (N)		Schließzeit (Sec.)				Verbrauch Hub x 2 (cm <sup>3</sup> )		Masse (Kg)
	Code 1	Code 2	Code 3	Code 3	Code 2	Code 1	Code 2	öffnen		schließen		Luft	Öl	
Type	Course / mors			Force de serrage à 6 bar (N)		Force de serrage à 50 bar (N)		Temps environ				Consommation course x 2 (cm <sup>3</sup> )		Masse en Kg
	code 1	code 2	code 3	code 3	code 2	code 1	code 2	ouverture		serrage		air	huile	
MPAF/3-135	6	3.5	1.9	13500	7020	8200	16500	0.15	0.25	0.15	0.2	127	49	28
MPAF/3-155	8	4.5	2.4	19100	10000	11100	22700	0.25	0.45	0.2	0.35	236	93	43
MPAF/3-200	10	6	3.1	25800	13470	13900	28500	0.35	0.6	0.3	0.4	426	180	80
MPAF/3-250	13	7.5	3.9	42800	22320	27700	56600	0.4	0.7	0.35	0.5	898	376	152
MPAF/3-310	16.5	9.5	5	69500	36420	45300	93200	0.6	1	0.5	0.7	1836	678	252

- Peso trasportabile calcolato con  $\mu = 0.1$  e  $f_s = 2$ . Con presa geometrica il valore potrà essere incrementato. La forza di presa è la somma aritmetica delle singole forze delle dita alla distanza di 15 mm dal piano griffa a 6/50 bar.
- Workpiece weight value at  $\mu = 0.1$  e  $f_s = 2$ . In case of form fit clamping these values may be higher. Gripping force is the arithmetic sum of the individual forces occurring at fingers, distance 15mm at 6/50 bar.
- Empfehlung für max. Werkstückgewicht gerechnet mit  $\mu = 0.1$   $f_s = 2$ . Bei Formschluss sind größere Massen möglich. Die Greifkraft ist die arithmetische Summe der an den Greifbacken auftretenden Einzelkräfte in Abstand 15mm bei 6/50 Bar.
- Masse transportable calculée avec  $\mu = 0.1$  e  $f_s = 2$ . Avec Prétension géométrique la masse pourrait être supérieure. La force de serrage est la somme arithmétique des forces individuelles des mors qui se forme à 15 mm à 6/50 bar.

**Versione con griffe dentate - code GB**  
**Version with serrated fingers - code GB**

**Version mit Spitzverzahnung - Ausf. GB**  
**Version morse à denture - code GB**

<b>Tipo</b>	Passo e Angolo
<b>Type</b>	Pitch and Angle
<b>Typ</b>	Verzahnungsgröße
<b>Type</b>	Pas et Angle
<b>MPAF 135-380</b>	1/16" x 90°
<b>MPAF 450</b>	3/32" x 90°

Type	A	B	C	D	E	F
MPAF 135	8	16	32	2.5	M8	10
MPAF 155	7	16	30	2.5	M8	12
MPAF 200	9.5	16	35	2.5	M10	14
MPAF 280	9	23	41	2.5	M12	17
MPAF 310	12	30	54	3.5	M16	21
MPAF 380	12	34	54	3.5	M16	21
MPAF 450	15	38	68	3.5	M20	25,5

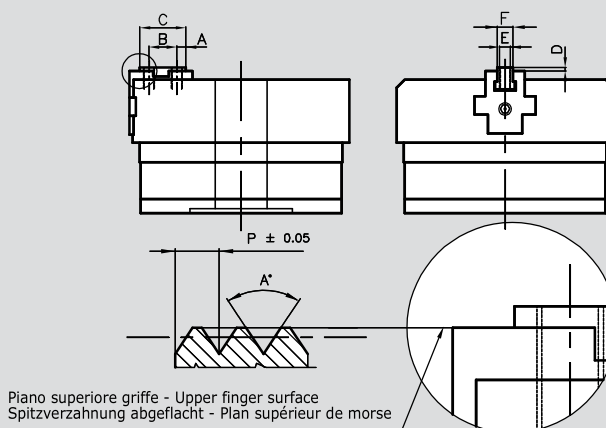

**Dati di carico ammissibili sulle dita**  
**Max adm. forces and moments at the fingers**

**Max. Kräfte und Momente am Grundbacken**  
**Données de charge admissible**

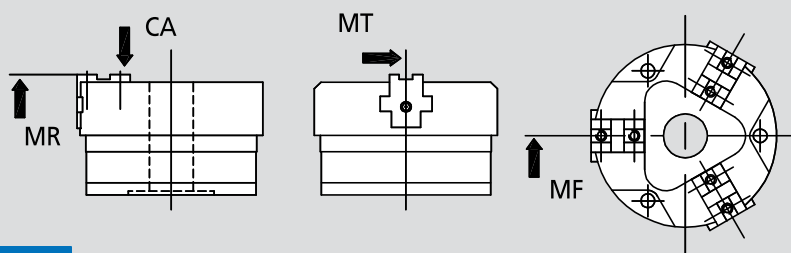

**Schema costruttivo**  
**Layout**

**Funktionprinzip**  
**Dessin d'ensemble**

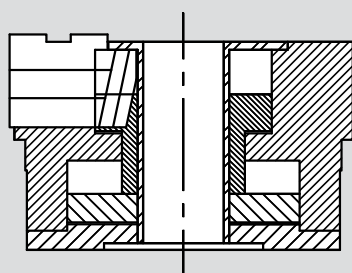

Type	CA (N)	MF(Nm)	MR(Nm)	MT(Nm)
MPAF/3 115	9000	80	110	80
MPAF/3 135	10000	120	280	95
MPAF/3 155	14000	150	360	130
MPAF/3 200	18000	200	410	170
MPAF/3 250	22000	240	480	220
MPAF/3 310	30000	300	600	270
MPAF/3 380	38000	410	750	400
MPAF/3 450	45000	520	900	500

**Esempio d'ordine**  
**Ordering data**

**Bestellbeispiel**  
**Exemple de commande**

Tipo	Indicare codice 1 o 2 o 3	Funzionamento PN (pneumatico) ID (idraulico)	Lubrificazione centralizzata cod. CL	Griffe dentate cod. GB	Centraggio e chiave cod. FC	Astina indicare cod. E	Pressurizz. su base cod. P	Alimentaz. su base cod. AB
Type	Indicate code 1 or 2 or 3	Actuation PN (pneumatic) ID (hydraulic)	Centralized lubrication code CL	Serrated fingers code GB	Centering and Key code FC	Rod indicate code E	Pressuriz. on base code P	Feeding on base code AB
Typ	Angeben code 1 od. 2 od. 3	Funktioesteile PN (Druckluft) ID(Hydrauliköl)	Zentral-schmierung Code CL	Spitzverzante Grundbacken GB	Kreuzversatz Code FC	Abfrage Code E angeben	Sperrluft Code P	Ausführung Grundplatte Code AB
Type	Signaler code 1 or 2 ou 3	Fonctionnement PN (pneumatique) ID (huile)	Graissage centralisé code CL	Morses striées code GB	Centrage et clavette code FC	Tige signaler code E	Pressuris. sur la base code P	Alimentat. sur la base cod. AB
MPAF/3 FL-200	C 3	PN	/	GB	/	/	/	/